

+ 1
+ 1

+

x Master Device

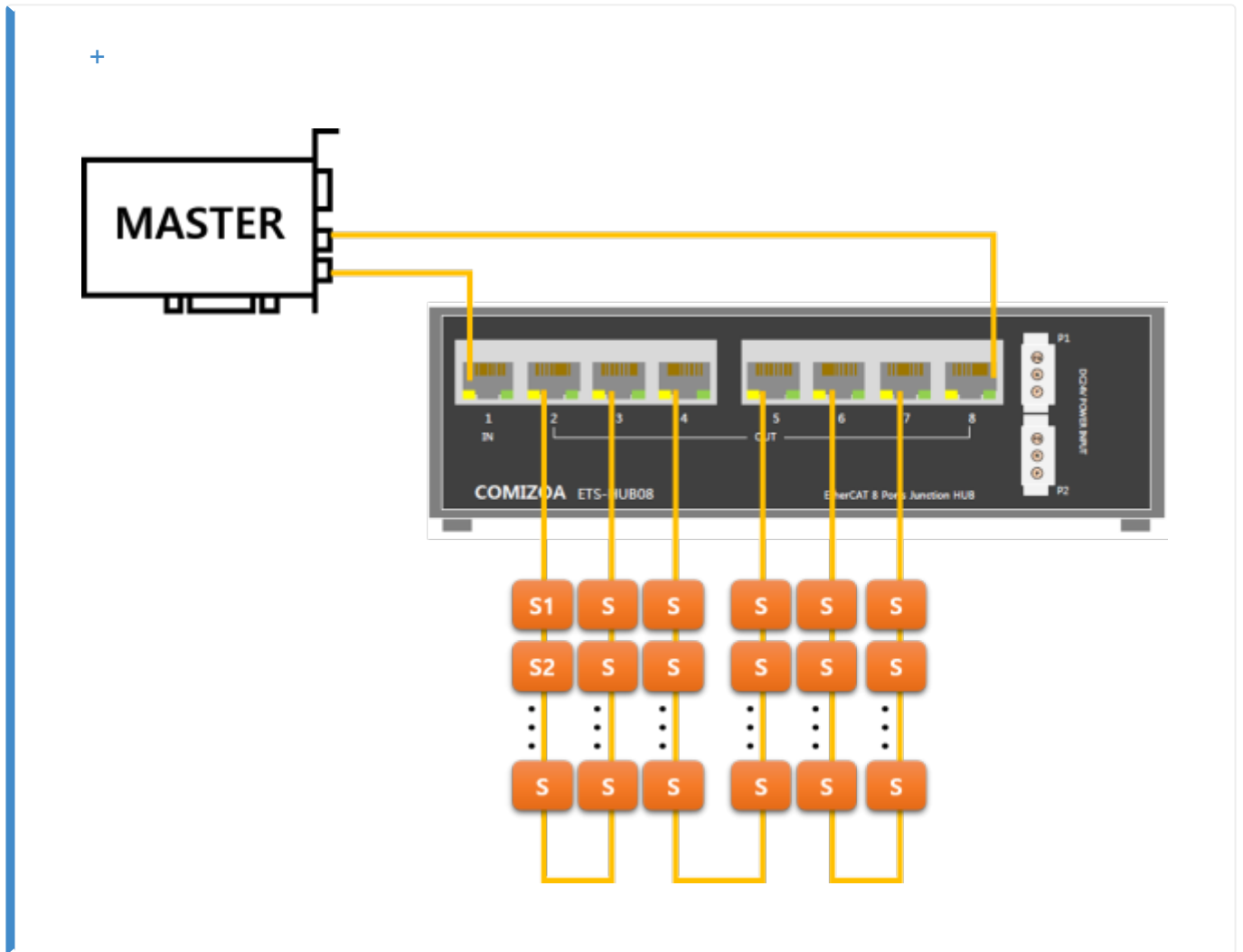

• Master Hub

, Hub

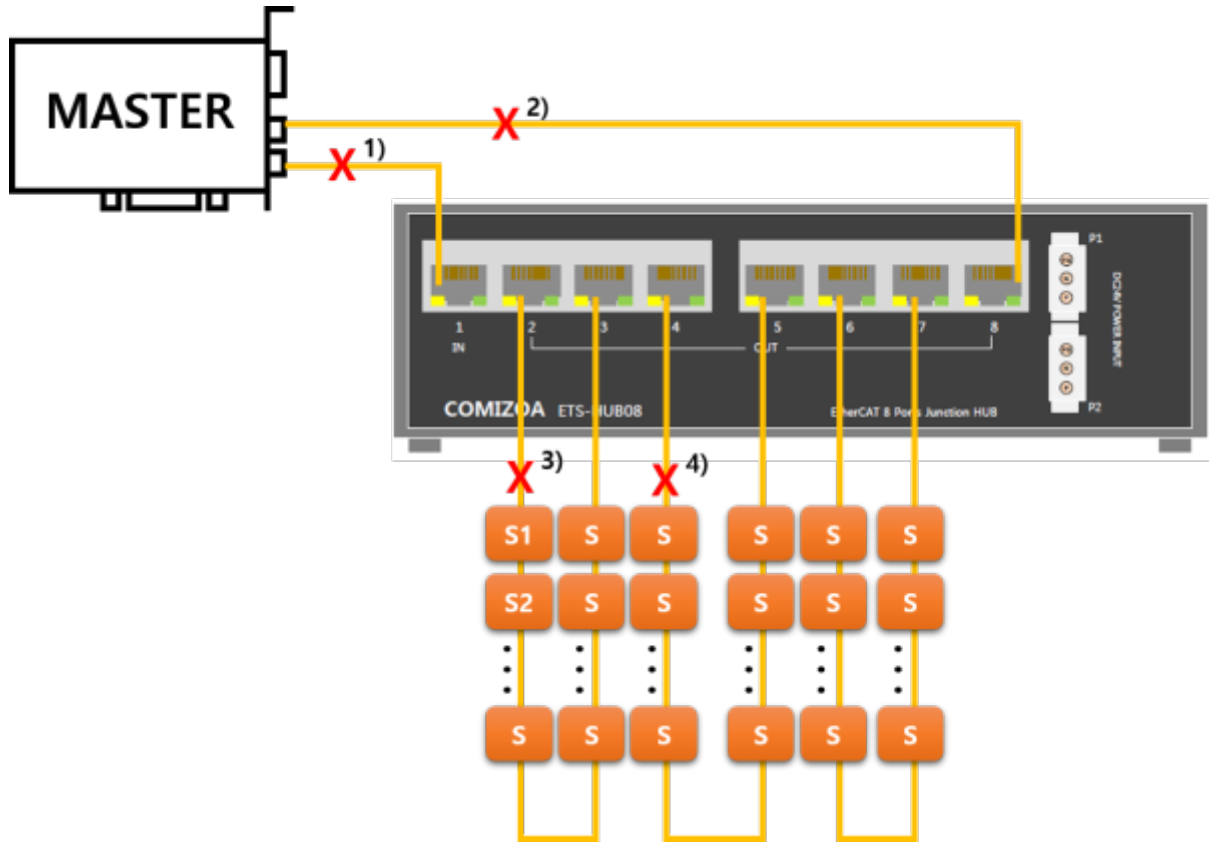

- 1) 2) 3) 4)

x 2 , Disconnect

x , Master Data가 가 , 가
가 , , 가

From:
<https://www.comizoa.com/info/> - -

Permanent link:
https://www.comizoa.com/info/doku.php?id=platform:ethercat:1_setup:05_topology:60_ring_ring&rev=1608097528

Last update: 2024/07/08 18:22